

2 Detector Wiring Circuit

**+12VDC Output @ 50 mA
to drive external circuitry,
typically positive coil side
of contact relay**

**Supply 12 volts to this input
for 2 seconds extra disable
time.**

**Wheel Counter
Reset.
(Optional)**

**NOTE: Any unused conductors and
all uninsulated shield and/or drain
wires should be connected to battery
neg. at source and connected
together inside sensors being daisy-
chained until reaching the end sensor
where they should be not connected
but left open but insulated so as not
to create a ground loop.**

Pair 1
+12VDC (White)
-12VDC (Black)

Black
White
Pair 2

Pair 1
+12VDC (White)
-12VDC (Black)

Black
White
Pair 2

#18 AWG (2) PAIR TWISTED AND SHIELDED

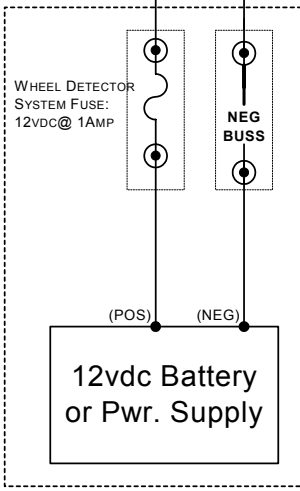
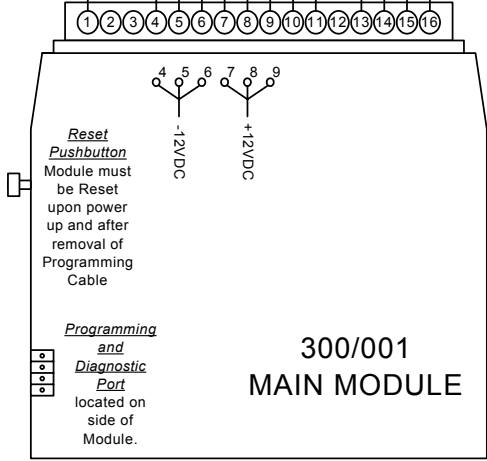
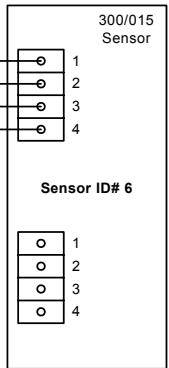
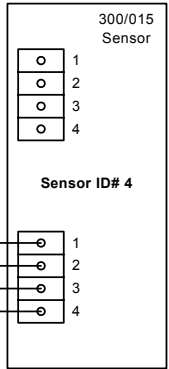

- Diagnostic LEDs**
- LED 1 ● Machine Enable
 - LED 2 ● Auto-Line Reverse
 - LED 3 ● Auto-Line Normal
 - LED 6 ● Power On + 12VDC
 - LED 7 ● Diagnostic LED
 - LED 11 ● 2 Second Extra Disable
 - LED 10 ● Module Reset
 - LED 12 ● Program Mode

**Note: When power is first applied the Wheel
Detector Module must be reset to enable the
Switch Machine.**

TITLE	DESCRIPTION	DATE	PAGE
300/2	ELECTRIC SCHEMATIC - SENSOR CONNECTIONS USING OKONITE H/D CABLE	10/26/2009	1 OF 1